



Product datasheet

Captair Flow 391 Smart

Vertical laminar flow cabinet

Providing an ultra-clean, dust free enclosure

Captair Flow Smart Vertical laminar flow cabinets are designed for tissue culture, non-pathogenic biological samples, food microbiology, cell culture, semi-conductor assembly,

Dust free workstation

- Protection against dust contamination
- Internal dust - free air quality achieved by high efficiency particulate filter (s) (HEPA H14 or ULPA U17)
- Optional carbon filter to protect samples from VOCs present in the laboratory room
- Class 5 air quality in the enclosure according ISO 14644-1

UV-C Germicidal lamp

- To sterilize the interior and contents before usage to prevent cross-contamination from the previous experiment
- This UV lamp switches off automatically is the operator opens the lower door by accident during decontamination

Easy to clean

- Work surface is easy to clean
- Seamless worktop with smooth corners (available in TRESPA®Top Lab PLUS laminate or Stainless steel 304 L)
- Non-porous material

Ergonomic design

- 4 models available for your handlings with large openings for easy access to your work
- Slanted sash provides an ergonomic position for comfort and productivity
- High luminosity, internal LED lighting > 800 lux

*With low dust level in the room



Download our
eGuard application



Captair Flow 391 Smart

Vertical laminar flow cabinet

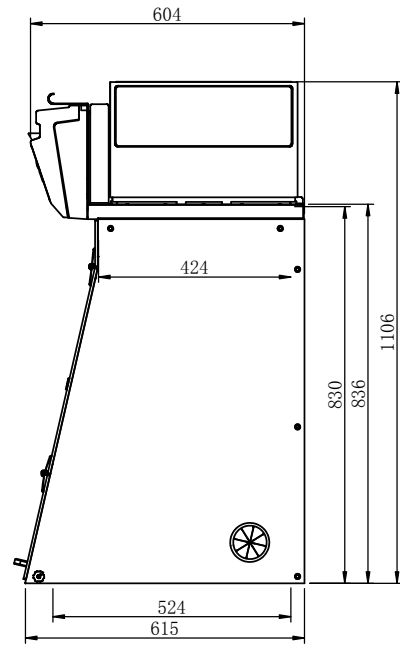
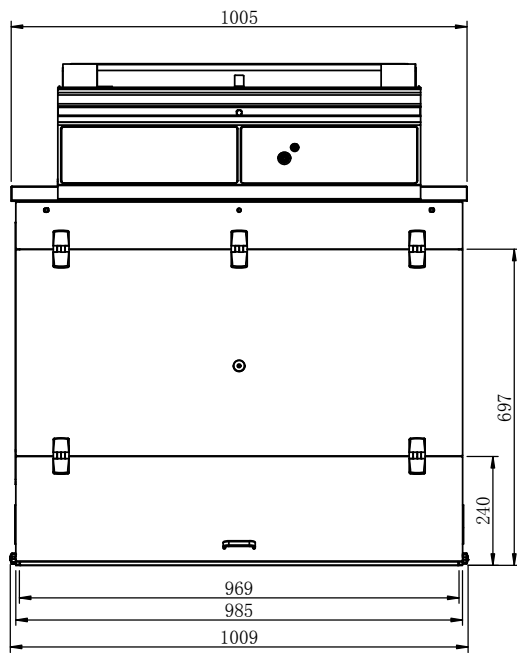

Please add 150mm between the last filter and the ceiling to allow good air recirculation and to replace filters easily

Work surfaces with built in spill tray

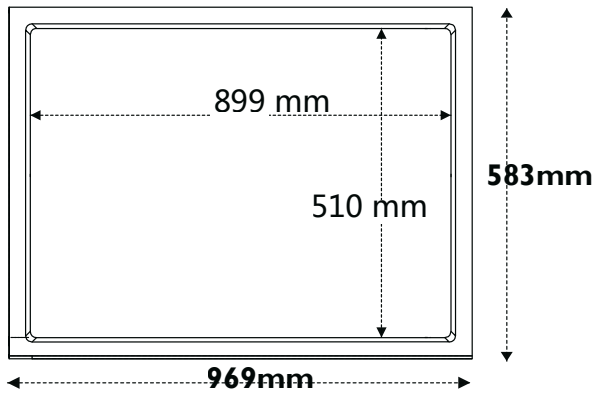

Trespa® Top Lab^{PLUS}

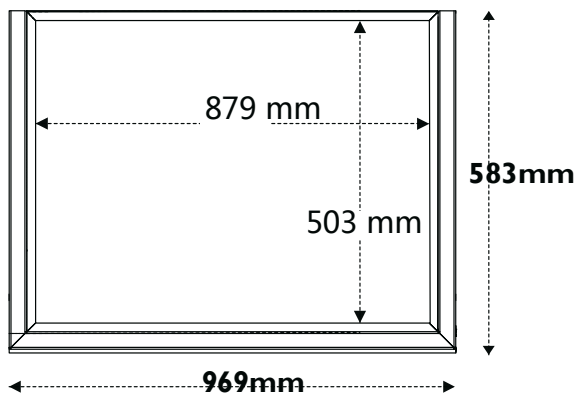

Stainless steel 304 L

Benchcap: fixed work bench

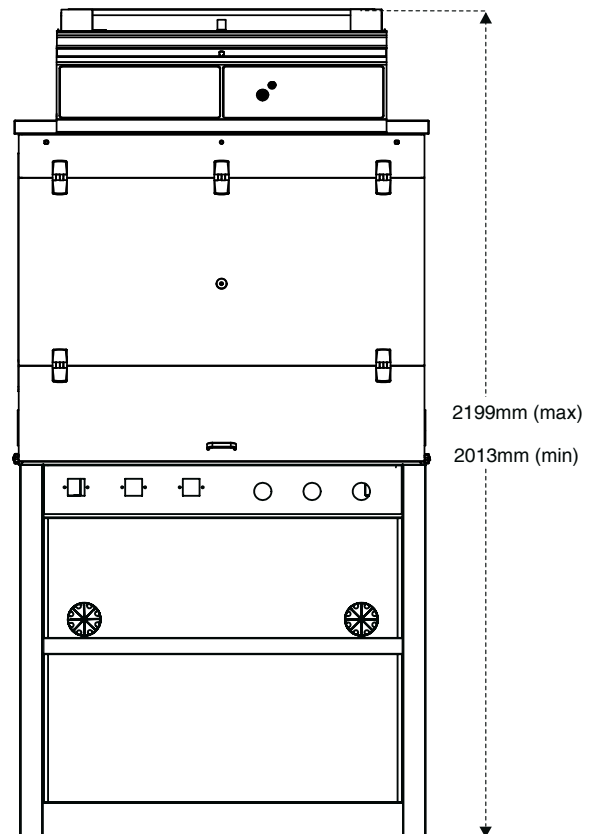

* For Mobicap: rolling cart, deduct 27 mm

Captair Flow 391 Smart

Vertical laminar flow cabinet



Designed with you in mind:
Our filtration column can be configured for your specific application requirements.

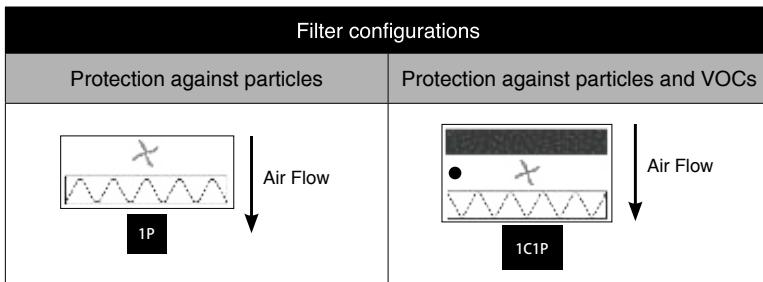

Filter types:

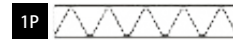

Particulate filtration for powders



Carbon filtration for gases and vapors

- Ventilation
- Molecode** : Automatic alarm to detect filter breakthrough

Model	1P	1C1P
Safety standards	NF EN 61010 - CE Marking - EN 1822:1998 (HEPA H14 & ULPA U17 Filters) Air quality within the enclosure: ISO class 5* EN 14644-1 standard	
External width (mm)	1005	
External depth (mm)	615	
External height min-max (mm)	1106-1292	
Internal width (mm)	969	
Internal depth min-max (mm)	424-524	
Internal height (mm)	830	
Voltage / Frequency (V-Hz)	100-240 / 50-60	
Air face velocity (m/s)	0.35	
Air flow (m ³ /h)	345	150
Fan setpoints (RPM)	2800	2100
Power consumption (W)	55	40
Decibel level (dBA)	62	52
Side and front panels	Chemical resistant acrylic	
Structure	Corrosion resistant electro-galvanized steel coated with anti-acid polymer	
Filtration module	Polypropylene	

Filtration

Particulate filter (1P)	HEPA H14 : This filtration technology traps particles larger than 0.1 μm with 99.995% efficiency according to the MPPS method set forth in the EN 1822-1 standard ULPA U17 : This filtration technology traps particles larger than 0.1 μm with 99.99995% efficiency according to the MPPS method set forth in the EN 1822-1 standard
Molecular filter (optional) (1C)	Adding a carbon filter to your enclosure allows protection of your samples from VOCs. AS filter: For organic vapors
Particulate pre-filter	Protect particulate filters from dust contained in the laboratory environment (only for 1P version)

Features

Internal lighting	LED - IP 44 - 6000K
	850 lux
eGuard app (Android or iOS)	Mobile app for real time remote control of Smart devices
Connectivity	RJ45 cable connection to view and change workstation settings (cable included)
Anemometer	Monitors a drop in pressure that indicates pre-filter or filter replacement is required
Side panel utility ports	2 per unit

Accessories

Benches	Rolling cart (Mobicap) or fixed bench (Benchcap)
Shelves	Internal metal sliding shelf (only for Benchcap)
Worktop	Stainless steel 304 L / TRESPA® TopLab PLUS
Molecode S	Automatic detection of VOC filter breakthrough



Erlab's state of the art Research & Development Laboratory relies exclusively on filtration

About Erlab

We provide safety, we protect your health

Erlab invented the ductless fume hood in 1968. With more than 50 years of experience in the field of chemical filtration and protection of laboratory personnel; we know the formula for safety. With Erlab, you will never have to wonder or worry if our products are safe. We build each one of the following 7 very important safety features into our products. Without all of them, your health and safety will be compromised.

1 Erlab R&D Laboratory

The engineers and chemists in our state-of-the-art R&D laboratory understand molecular filtration. We are committed to designing products that are safe and of the highest quality, strive to improve our products, and continuously develop new products that provide greater protection in the laboratory.

2 Strict Safety Standards

We hold ourselves to the highest standard and adhere to the strict AFNOR NF X 15-211: 2009 filtration safety standard as endorsed by ANSI Z9.5-2012.

3 A Published Chemical Listing

It all begins here. Without this listing, we are not compliant with AFNOR NFX 15-211. Our in-house laboratory tests, as well as independent testing, to verify the retention capacity of over 700 chemicals for our filters.

4 Independent Testing

Erlab filters have been independently tested multiple times at various concentrations guaranteeing that our safety solutions all adhere to the strict performance criteria of the AFNOR NF X 15-211:2009 standard assuring that the emission concentration at the filter exhaust will always be lower than 1% of the TLV.

5 Application Questionnaire (Valiquest)

Our laboratory specialists will recommend the appropriate filtration fume hood, type of filter, and personalized advice.

6 Certificate of Validation for the chemicals used in the hood

A certified PhD chemist issues a Certificate of Validation with a list of the chemicals approved for use in the hood.

7 Our Safety Program

We back up our products 100%. This program includes your specialized chemical evaluation, validation of your hood upon installation, and a filtration safety specialist at your service to ensure that your hood is operating to its full potential during its entire lifetime of use.

France
+33 (0) 2 32 09 55 80 | ventes@erlab.net

United States
+1 800-964-4434 | captairsales@erlab.com

China
+86 (0) 512 5781 4085 | sales.china@erlab.com.cn

Germany
0800 330 47 31 | verkauf@erlab.net

United Kingdom
+44 (0) 1722 341 940 | salesuk@erlab.net

Italy
+39 (0) 2 89 00 771 | vendite@erlab.net

www.erlab.com



Celebrating 50 years
of innovation in filtration

